

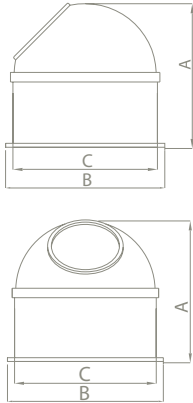

Mini-Hansita | Desk Binnacle

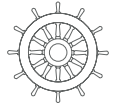

Mini- Hansita I

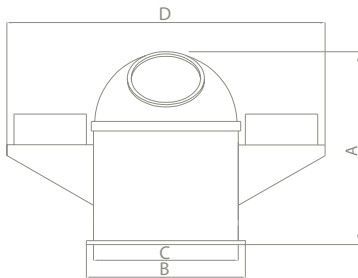

Mini- Hansita II

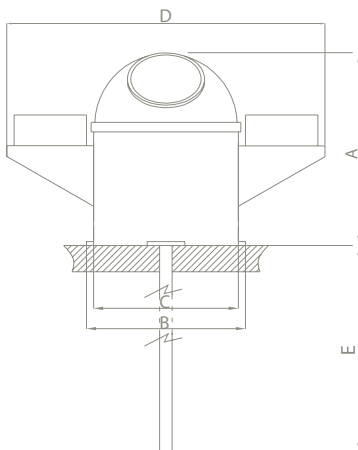

Mini- Hansita III

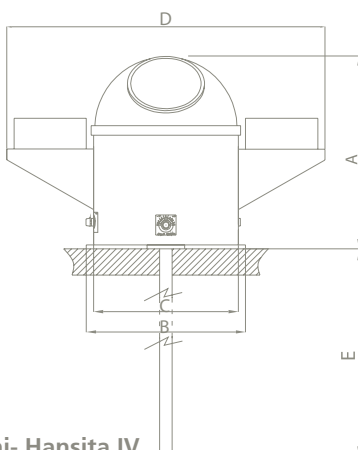

Mini- Hansita IV

Product Description

Gimballed "Consemi" magnetic compass with 125 mm diameter of the card, mounted in the Mini-Hansita binnacle on the bride console providing the helmsman with direct view of the compass card.

Suitable for coastal vessels and other small sea going vessels, that, depending on the chosen model can go from the bare compass on a plain binnacle, up to a compass in a binnacle with full compensation except the flinders bar.

Two different size binnacles depending on the chosen corrector means. All made of fiber glass reinforced plastic with grooves in their base thus permitting a correct alignment with fore and aft line of the vessel.

Total weight including compass:

- Mini-Hansita I: 10 Kg.
- Mini-Hansita II: 22 Kg
- Mini-Hansita III: 22,5 Kg
- Mini-Hansita IV : 23,5 Kg

Corrector means	D-Correctors	Heeling magnet	B+C Correctors	Flinders bars
Mini hansita I	No	No	No	No
Mini -hansita II	Yes	No	No	No
Mini hansita III	Yes	Yes	No	No
Mini -hansita IV	Yes	Yes	Yes	No

Compasses Approvals

BSH homologation nº: BSH/46122/4012230/12

USCG homologation nº: 165.101/EC0735. 4012230

Test Standards based on Directives 2010/68/EC and 2011/75/EC:

- IMO Resolution A.382 (X)
- IMO Resolution A.694 (17)
- ISO 1069 Ed.1.0.1973
- ISO 25862 Ed.1.0.2009
- IEC 60945 Ed.4.0.2002
- IEC 60945 Ed.4.0.2008

	Mini-Hansita I	Mini-Hansita II	Mini-Hansita III	Mini-Hansita IV
A	300	400	400	400
B	330	330	330	330
C	330	330	330	330
D		660	660	660
E			430	430