S.NO.

AIR HORN



IBUKI KOGYO CO., LTD.

HEAD OFFICE 7-28, 1-chome, Takadono, Asahi-ku, Osaka, 535-0031 Japan.
Tel. Osaka (06) 6922-5115
Fax. Osaka (06) 6924-3567

TOKYO OFFICE Honmoku Building, 5th Floor,
1-22, Kanda suda-cho, Chiyoda-ku, Tokyo, 101-0041 Japan.
Tel. Tokyo (03) 3251-4153
Fax. Tokyo (03) 3251-4158

TABLE OF PLAN
計 画 表

ORDER NO.
工事番号

13-1894

S. NO.

AIR HORN
エアホーン

NAME 品名	PRESSURE 圧力 (MPa)	DWG. NO. 図面番号	QUANTITY PER VESS. 数量/1隻	PAINTING 塗装色
Whistle (Above 130dB) 汽笛 (130dB 以上) A100EH AIR HORN エアホーン WITH HEATER (300W) & THERMOSTAT ヒータ及びサーモスタット付	0.6~1.0	OUTLINE 外形図 SOJ-1240C, A-5	1	N9.5
		CONSTRUCTION 構造図 SSJ-1240C		
		PARTS LIST 部品表 PJ-1240C		
		OUTLINE 外形図		
		CONSTRUCTION 構造図		
		PARTS LIST 部品表		
		OUTLINE 外形図		
		CONSTRUCTION 構造図		
		PARTS LIST 部品表		
TIME CONTROLLER タイムコントローラ		EAA-5705	1	N3.0
SYSTEM DIAGRAM 系統図		SWJ-13-1894		
WIRING DIAGRAM 接続図		SWJ-STM-8Z-2		

SOURCE 電 源	MAIN CIRCUIT 主 回路	DC24V AC230V, 1φ, 60Hz	AUTO. FOG SIGNAL			
	CONTROL CIRCUIT 操 作 回路	DC24V	SOUND - REST - SOUND - REST			
NOTE 注 記	NAME PLATE 銘 板	ENGLISH 英 文	1 BLOW ... 5 - 55			Sec.
			2 BLOW ... 5 - 2 - 5 - 48			Sec.
			3 BLOW ... 5 - 1 - 1 - 1			Sec.
				- 1 - 51	Sec.	
			CYCLE ... 60	Sec.		

MAY. 10. 2013

IBUKI KOGYO CO., LTD.

INSTRUCTIONS

1. Items relating to safety

1.1. WARNINGS

Completely clean the air line to remove all dusts and rusts, etc. from the line before installing the whistle.

Do not put face and hands close to the blowout hole.

When servicing the whistle at a high place, provide a safety scaffold and wear a lifeline.

Always switch off power first when working on the whistle.
Make sure that no voltage exists.

Before sounding the whistle for test, be sure the area is cleared of all unauthorized personnel and all personnel in the area wear ear protection (e.g. earplugs).

Close the air supply valve and bleed all pressure from the air line before accessing the air horn for servicing (e.g. replacement of diaphragm, valve adjustment).

Do not put face and hands close to the blowout hole.

2. Electric shock safety guidelines

2.1. General

2.1.1. Effect of electric shock to human body

- (1) Electric shock has very high degree of risk of bodily injury.

Even relatively low, the current flowing through heart, lung and other critical organs can result in personal injury or even death.

- (2) In general, when working with low AC volts, for example, around 100 volts, people tend to ignore the risk involved.

Remember that a power source capable of flowing 50 mA at 100 VAC, 60/50 Hz can be dangerous to human body.

100 mA current can result in serious personal injury from electric shock.

2.1.2. Symptoms of electric shock

Typical symptoms of electric shock are usually not chronic.

In the case of unconsciousness or apparent death, do not give the victim of electric shock up for dead.

Intead, immediately render first aid and resuscitation such as artificial respiration and heart massage.

Continuous resuscitation for several hours may revive by victim.

- (1) In the case of breathless, perform artificial respiration until the respiratory center recovers the respiratory function.
- (2) In the case of serious electric shock, the face of the victim turns pale, the heart palsates faintly or stops.
- (3) In the case of unconsciousness, the victim's body becomes rigor in three minutes.

2.2. To prevent electric shock

Personnel in charge of operation, maintenance, repair, etc., of the whistle and the supervisor must strictly observe applicable electric safety standards and regulations and implement the following special precautions and handling techniques to assure positive prevention of electric shock.

- (1) Personal injury and property damage caused by electric shock often resulted from live power line which should have been off.

Verify that the power switch is off and verify that power line is dead by using a voltmeter and the like.

(2) Do not solely rely on safety and protective system.

Always protect against failure of these system.

(3) Wear rubberized/insulated gloves and shoes.

Place insulating material (e.g. rubber mat) between the surface.

(4) Do not turn on and off power during service except for unavoidable case.

When power is off during service, the work area should be designated to caution people that power must be kept off.

(5) When operating the power switch, always use the right hand while keeping the left hand off the body (stretch the left hand backward).

(6) Always have another member of staff stand near the power disconnecting device capable of turning off power quickly in the case of electric shock.

INSTRUCTIONS

IBUKI A100EH TYPE AIR HORN

(Whistle for vessels of 20m or more but less than 75m)

1. General

The IBUKI Air Horn is equipped with diaphragms which are vibrated by compressed air. The air supply can be controlled via a solenoid valve electrically or manually.

2. Operation

Refer to the instructions for IBUKI Whistle Controller.

3. Installation

(1) The whistle shall be placed as high as practicable on the vessel, in order to reduce interception of the emitted sound by obstructions and also to minimize hearing damage risk to personnel.

(2) The whistle shall be firmly fixed with bolts and nuts.

(3) The place for the whistle shall be sufficiently large for inspection and maintenance, and behind the whistle a space of at least 200mm is required to exchange diaphragms.

4. Disassembly and reassembly

4.1. Disassembly ... Refer to the Drawing No. SSJ-1240C

(1) Remove the heater cover.

(2) Screw off the back ring and take out the diaphragms.

(3) Remove the magnet terminal box cover, and disconnect cable wires from the terminal block.

(4) Screw off the magnet yoke clamping bolt, and remove the magnet yoke with the magnet coil, the magnet spring and the plunger.

(5) Disconnect the magnet coil lead wire and the rectifier (diode) from the terminal block, and pull out the magnet coil.

(6) Remove the magnet base and the valve box cover, and take out the valve spring and the valve from the valve box.

(7) Remove the heater terminal cover, and screw off the heater setting nut, and then remove the heater from terminal box.

4.2. Reassembly

- (1) For reassembly the described procedure for disassembly is reversed.
- (2) Thoroughly clean the fitting joints for reassembly.
- (3) Make sure that all fastening/clamping bolts are fastened securely.

Be sure to avoid undue application of force in fastening them.

5. Precautions

- (1) Be sure to turn off the power switch when the cover of the whistle terminal box is opened.
- (2) Be sure to close the air main valve and purge air from the piping before hand is put into the whistle e.g. for replacing the diaphragms, adjusting the valve.
- (3) The diaphragms are to be attached in the following order.

The back ring shall be adjusted to make a clear sound on blowing test.

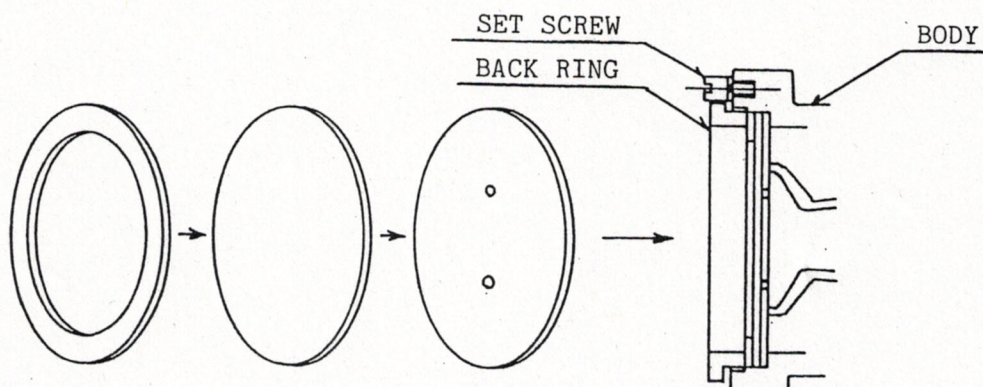

- (4) Experience shows that ingress of foreign matter into the whistle operating valve can often cause damage to the valve seat.

Therefore, be sure to sweep clean the air piping before installing the whistle.

An air filter is recommended to be installed upstream of the whistle.

- (5) The heater is to be used only when the ambient temperature is below 0°C, and there is a risk of freezing.

The heater switch is to be turned off when the ambient temperature is above 0°C.

WHISTLE TIME CONTROLLER
(AUTO FOG SIGNAL CONTROLLER)

STM-8Z

INSTRUCTION MANUAL

Before operate this system , please read this instruction manual.



IBUKI KOGYO CO., LTD.

INDEX

	Page
1. General	3
2. Auto Fog Signal	3
3. Other Signal	3
4. Operation	4
4 - 1 Control Panel	4
4 - 2 Power / Heater	5
4 - 2 - 1 Power Source	5
4 - 2 - 2 Heater	5
4 - 3 Whistle & Light Select	5
4 - 4 Auto Fog Signal	5
4 - 5 Free Signal	6
4 - 5 - 1 Free Blow	6
4 - 5 - 2 Signal Light Switch	6
4 - 6 Dimmer	6
5. Replacement of Parts	7
6. Maintenance	8
7. Trouble Shootig	8
8. Caution	9

TIME CONTORLLER (STM-8Z)

INSTRUCTION MANAUAL

1. GENERAL

IBUKI Whistle time controller STM-8Z is operation control unit for Whistle and Navigation/Morse signal light.

Fog signal is generated from the preset pattern related to IMO regulation.

2. AUTO FOG SIGNAL

The preset signal pattern is following. Each pattern is regulated on International Regulations for Preventing Collisions at Sea (Colreg), Rule 35.

AUTO FOG SIGNAL	
1-BLOW —	60sec cycle UNIT: SEC. 5
A power driven vessel making way through the water	
2-BLOW — —	60sec cycle 5 2 5 2 5
A power driven vessel underway but stopped and making no way through the water	
3-BLOW — . .	60sec cycle 5 1 1 1 5 1 1 1
A vessel not under command, restricted in her ability to manoeuvre, constrained by her draught, engaged in towing or pushing another vessel	

3. OTHER SIGNAL

On occasion of vessel, there are kinds of signal pattern. See the details on Colreg Parts D. "SOUND AND LIGHTING SIGNALS"

4. OPERATION

4 - 1 CONTROL PANEL

The function of Control Panel and details of each switch and indicators is following.

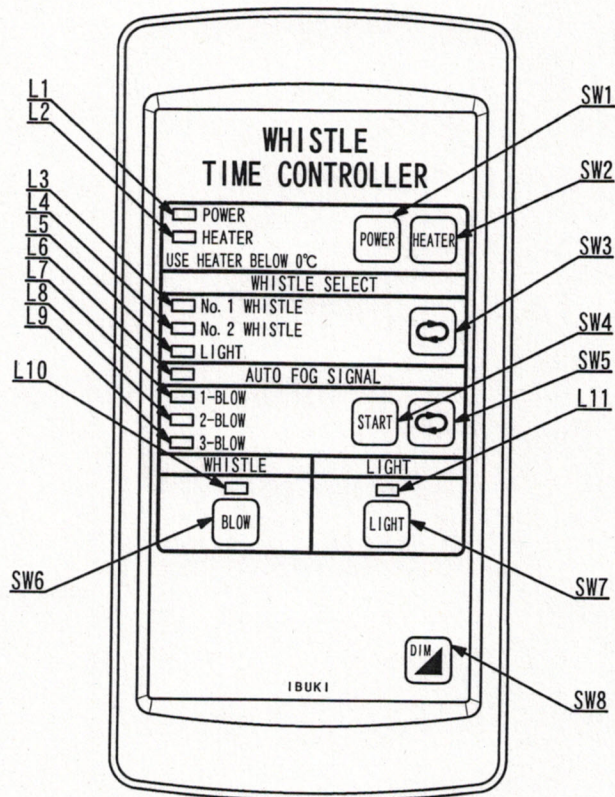

	DESCRIPTION	REMARKS
L1	POWER LAMP	LED
L2	HEATER LAMP	LED
L3	No1 WHISTLE SLECT LAMP	LED
L4	No2 WHISTLE SELECT LAMP	LED
L5	LIGHT SELECT LAMP	LED
L6	AUTO FOG ACTIVATE LAMP	LED
L7-L9	AUTU FOG SELECT LAMP	LED
L10	FREE BLOW SW LAMP	LED
L11	LIGHT SW LAMP	LED
SW1	POWER SWITCH	PUSH BUTTON SW
SW2	HEATER SWITCH	PUSH BUTTON SW
SW3	WHISTLE& LIGHT SELECT SWITCH	PUSH BUTTON SW
SW4	AUTO FOG START SWITCH	PUSH BUTTON SW
SW5	AUTO FOG SELECT SWITCH	PUSH BUTTON SW
SW6	FREE BLOW SWITCH	PUSH BUTTON SW
SW7	LIGHT SWITCH	PUSH BUTTON SW
SW8	DIMMER SWITCH	PUSH BUTTON SW

4 - 2 POWER / HEATER

4 - 2 - 1 POWER SOURCE

Power Switch (SW1) is power on and off .Power is switched over whenever push .Power lamp(L1) is lit when the power is on.

4 - 2 - 2 HEATER

Heater Switch (SW2) is heater on and off.Heater is used in cold area for whistles. Heater is switched on and off whenever push. Heater lamp(L2) is lit when the power is on.

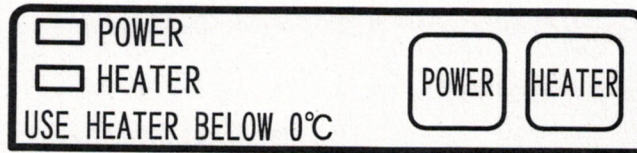

WARNING

Be sure to operate the heater below 0 degree on outdoor temperature. When not in use, heater should be switched off.

4 - 3 WHISTLE & LIGHT SELECT

Whistle & Light Select switch (SW3) is selection of whistle and light in operation .Operation is switched over as following whenever push. When the light is selected, whistle and light are synchronized operation.

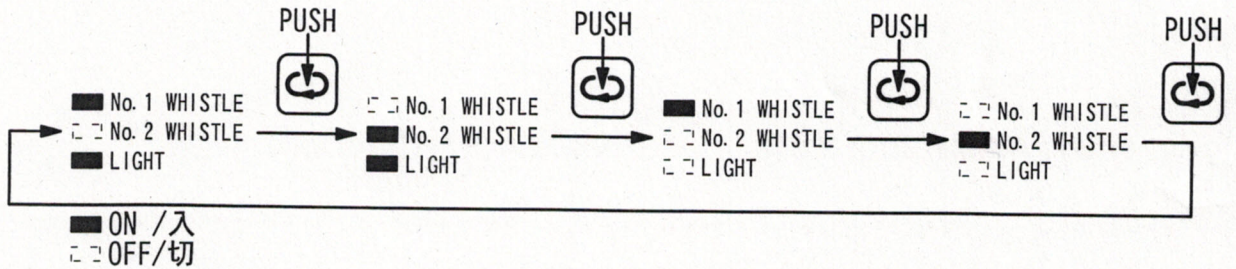

4 - 4 AUTO FOG SIGNAL

Auto Fog Select switch (SW5) is selection of signal pattern, Auto Fog Start switch (SW4) is blow switch. Auto Fog activate lamp (L7) is lit when the auto fog signal generator is activated.

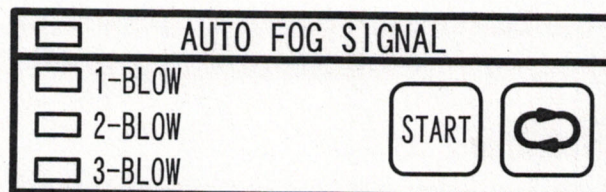

4 - 5 **FREE SINGAL**

Free signal is blown by means of push button.

4 - 5 - 1 **FREE BLOW(WHISTLE)**

Selected whistle is blown when push Free Blow Switch (SW6) switch. Blow is continuous on pushing. Indication lamp is lit at all times to indicate the location.

4 - 5 - 2 **SIGNAL LIGHT SW**

Navigation light is lit when push Light Switch (SW7) switch. Lighting is continuous on pushing. Indication lamp is lit at all times to indicate the location.

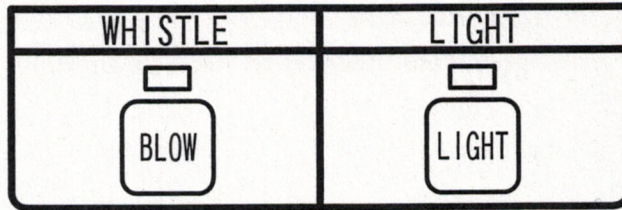

4 - 6 **DIMMER**

Brightness is adjustable to push the dimmer switch (SW8).Continuous dimmer is available to keep pushing.



5. REPLACEMENT OF PARTS

a) Fuse

After turn off the source, remove the panel cover to replace the fuse.

Fuse is installed on print circuit board of the relay terminal board.

Panel cover should be fixed after replace.

The list of fuse is following...

Code	Description	Use
Fu1	125V 1A	For control circuit (Panel side Mount)
Fu2	250V 10A	Main Power
Fu3	250V 10A	Main Power

b) Relay

After turn off the main/emergency source, remove and replace the relay by pliers. The list of relay is following...

Code	Description	Use
Ry1	2a G6B-2214P	No1 Whistle
Ry2	2a G6B-2214P	No2 Whistle
Ry3	2a G6B-2214P	No1 Heater
Ry4	2a G6B-2214P	No2 Heater
Ry5	2a G6B-2214P	Light

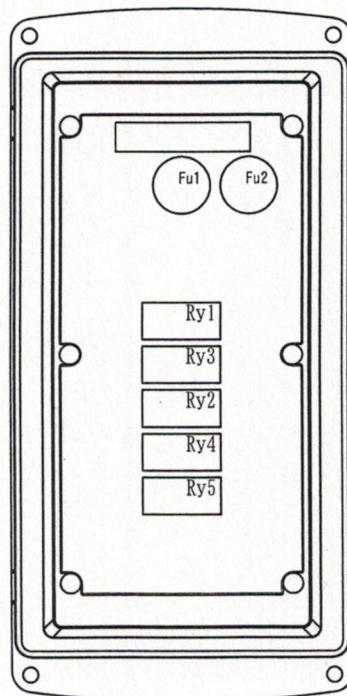

Location of fuse and relay

6. Maintenance

Maintenance and operation test are following instruction.

Period	Item	Description	Remark
1 month	Blow test	Check the blow in order when push free blow switch(SW6).	Refer to "4 - 4"
1 year	Operation test	Check the above and auto fog signal pattern in order.	Refer to "4 - 4/4 - 5"

7. Trouble shooting

The following is trouble-shooting in case of failure operation. Should the failure not rectified, contact the agent or maker.

Working	Condition	Check Method	Cause
No Operation	Power indication light is out when switch on power.	Check the power supply to terminal R-S	Power is not supplied. → To be input the power
		Check the fuse to be normal	Burn-out fuse → Replace a fuse after rectify the problem
	No operation when switch on power and indication lamp is lit.	→	→ Contact the maker
Not Blow	No blow when push the free blow switch.	No output the terminal M1-M2 and M3-M4.	Burn-out fuse → Replace a fuse after rectify the problem Failure on relay → Check the Ry1 and Ry2. Then replace them if necessary
		Normal output on the terminal M1-M2 and M3-M4.	Failure on whistles → Check & Repair

Irregular Work	No stop blowing	No output the terminal M1-M2 and M3-M4 after push free blow switch	Failure on whistles →Check & Repair
		Normal output on the terminal M1-M2 and M3-M4 after push free blow switch	Failure on time controller →Check & Repair
	No fixed auto fog signal	Normal output on the terminal M1-M2 and M3-M4	Failure on whistles →Check & Repair
		No fixed output on the terminal M1-M2 and M3-M4	Failure on time controller →Change PW unit

1 0 . CAUTION

Caution

Be sure to power off and confirm no voltage on terminal to do maintenance.

Caution

Be sure to power off and confirm no voltage on terminal to do wiring.

Caution

Be sure that no attendant is around the whistles. Wear earplugs in case attend.

Caution

Be sure to operate the heater below 0 degree on outdoor temperature. When not in use, heater should be switched off.

Caution

Be sure to arrange regular maintenance and fix the problem in case of failure operation.

Whistle (Above 130dB)
汽笛 (130dB 以上)

A100EH AIR HORN
エアホーン

WITH HEATER (300W)
& THERMOSTAT
ヒータ及びサーモスタット付

MASS
質量

12.7 kg

1/3 rd-OCTAVE BAND LEVEL
オクターブバンドレベル

130 dB/1m

FUNDAMENTAL FREQUENCY
基本周波数

APPROX.
約 310 Hz

CONSUMPTION
消費量

FREE AIR
自由空気 15 l/s.

AIR PRESSURE
空気圧力

0.6~1.0 MPa

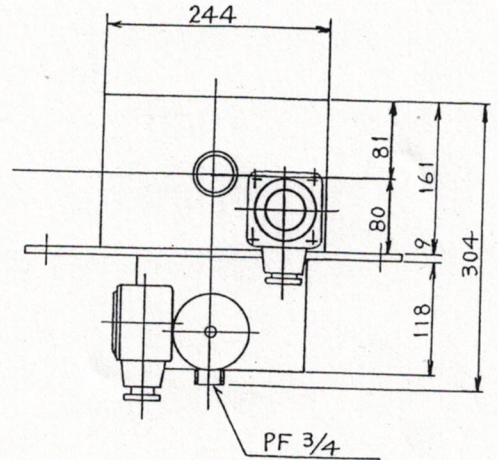
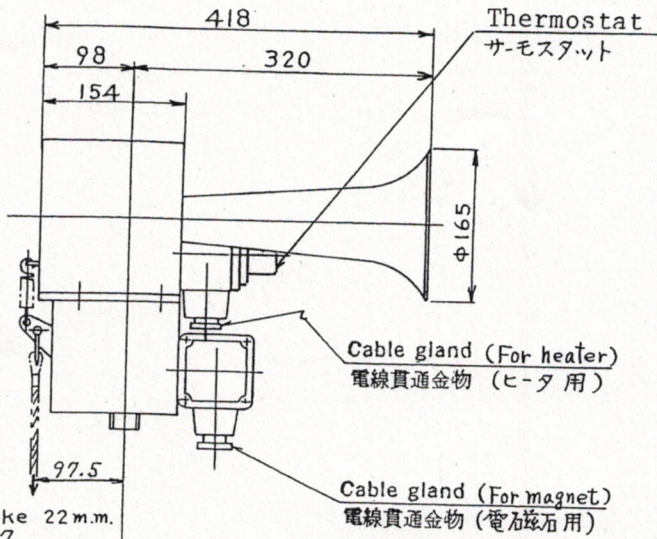

Lever stroke 22m.m.
レバーストローク

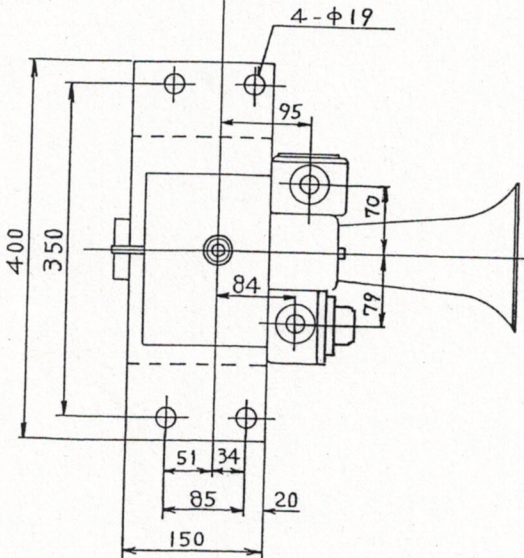

View from under

NO.	SOURCE 電源	EXCITING CUR. 励磁電流
1	DC 24V	0.8 A
2		



WORK NO.

IBUKI KOGYO CO., LTD.

DWG. NO.

SOJ-1240C

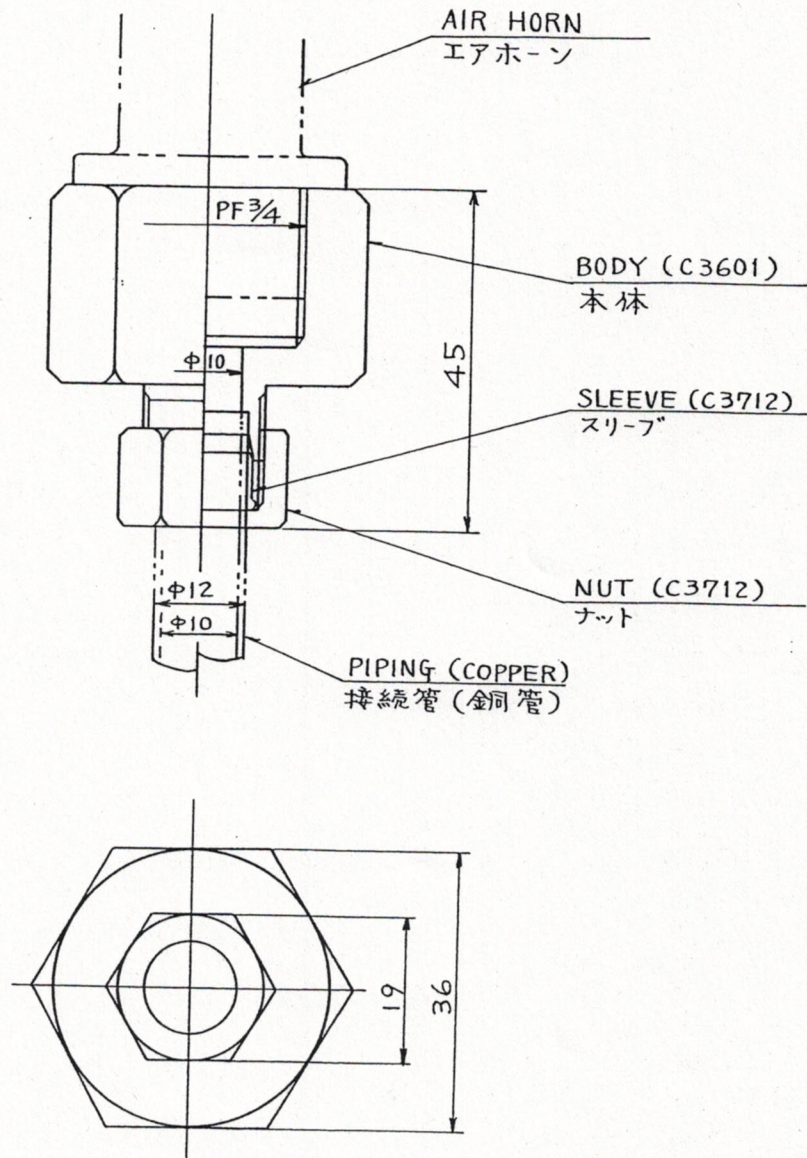

Ø 12

PIPE FITTINGS

くい込み継手

MASS 質量	0.25 kg	D.W.N	qu qu	DATE	FEB. 15. 1980
		C.K.D.		DWG. NO.	A-5
IBUKI KOGYO CO., LTD. OSAKA JAPAN					

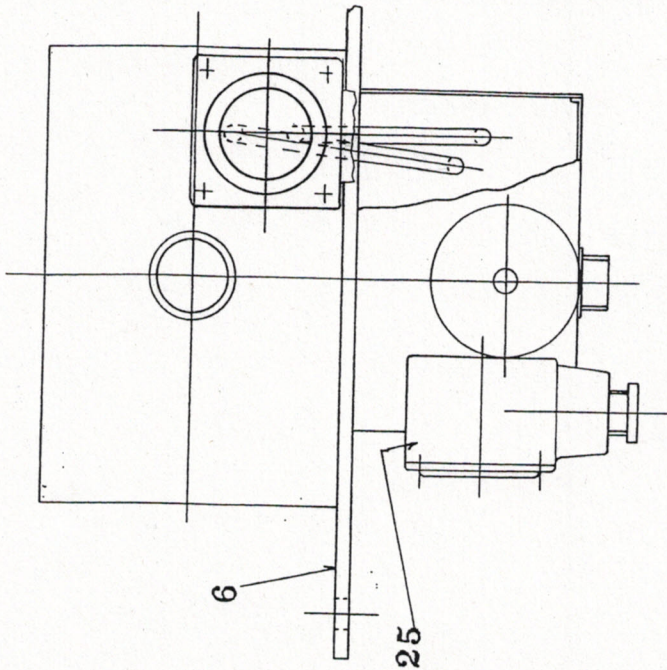
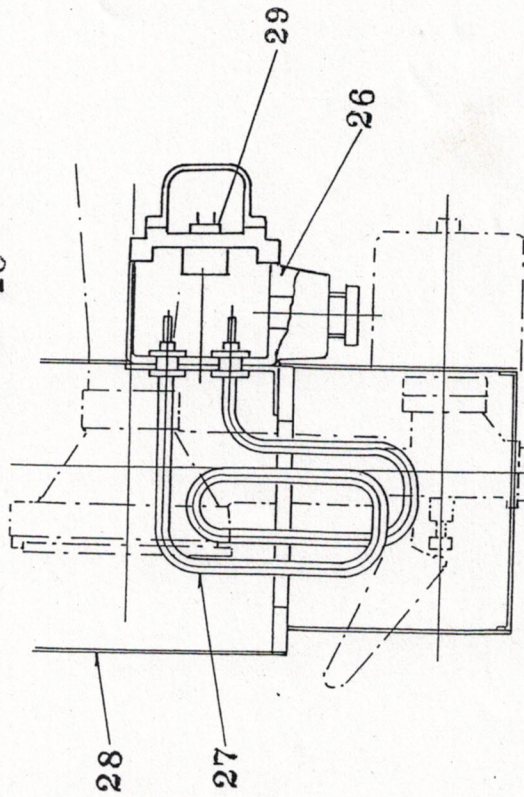
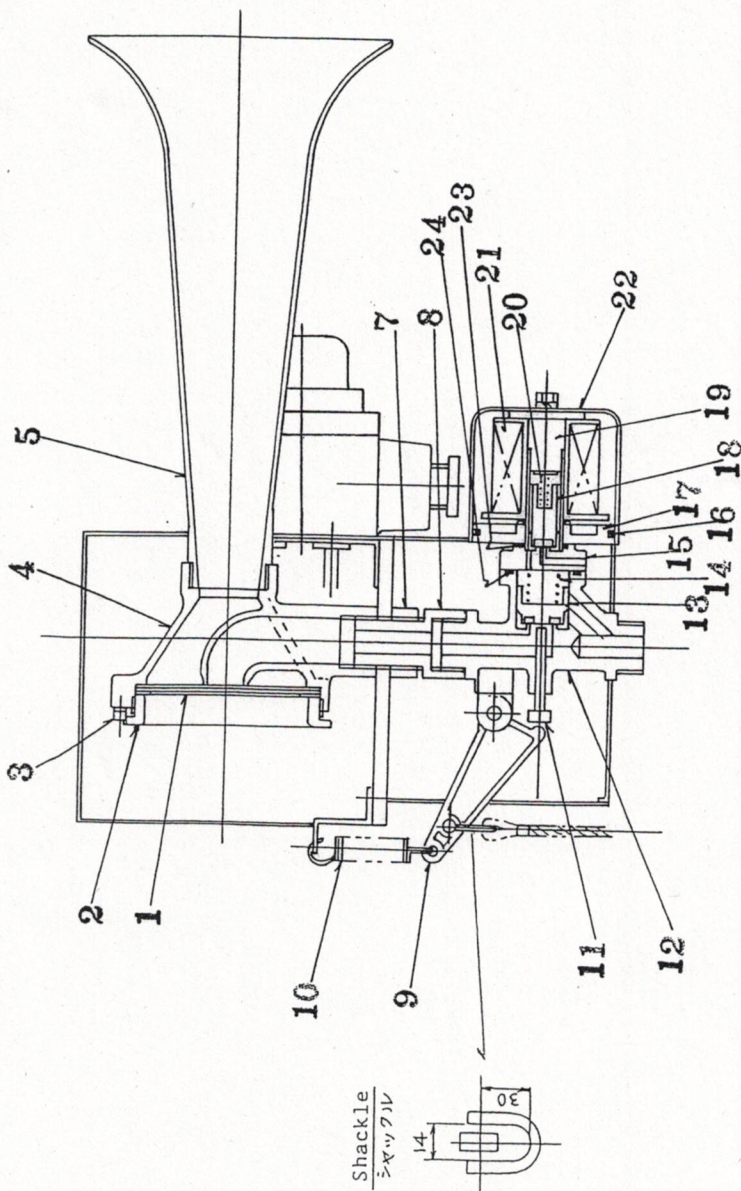

結線図

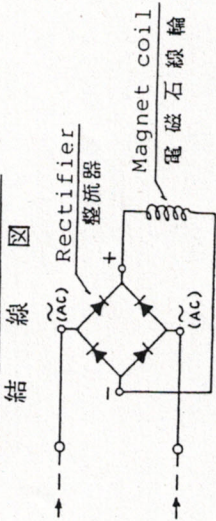

Whistle (Above 130dB)
汽笛 (130dB 以上)

A100EH 形 AIR HORN
エアホーン
CONSTRUCTION VIEW

構造図

D.W.N. *Shimizu* D.A.T.F. FEB. 27. 1979

C.K.D. DWGNO. SSJ-1240C

IBUKI KOGYO CO., LTD. OSAKA JAPAN

TIME CONTROLLER
タイムコントローラ

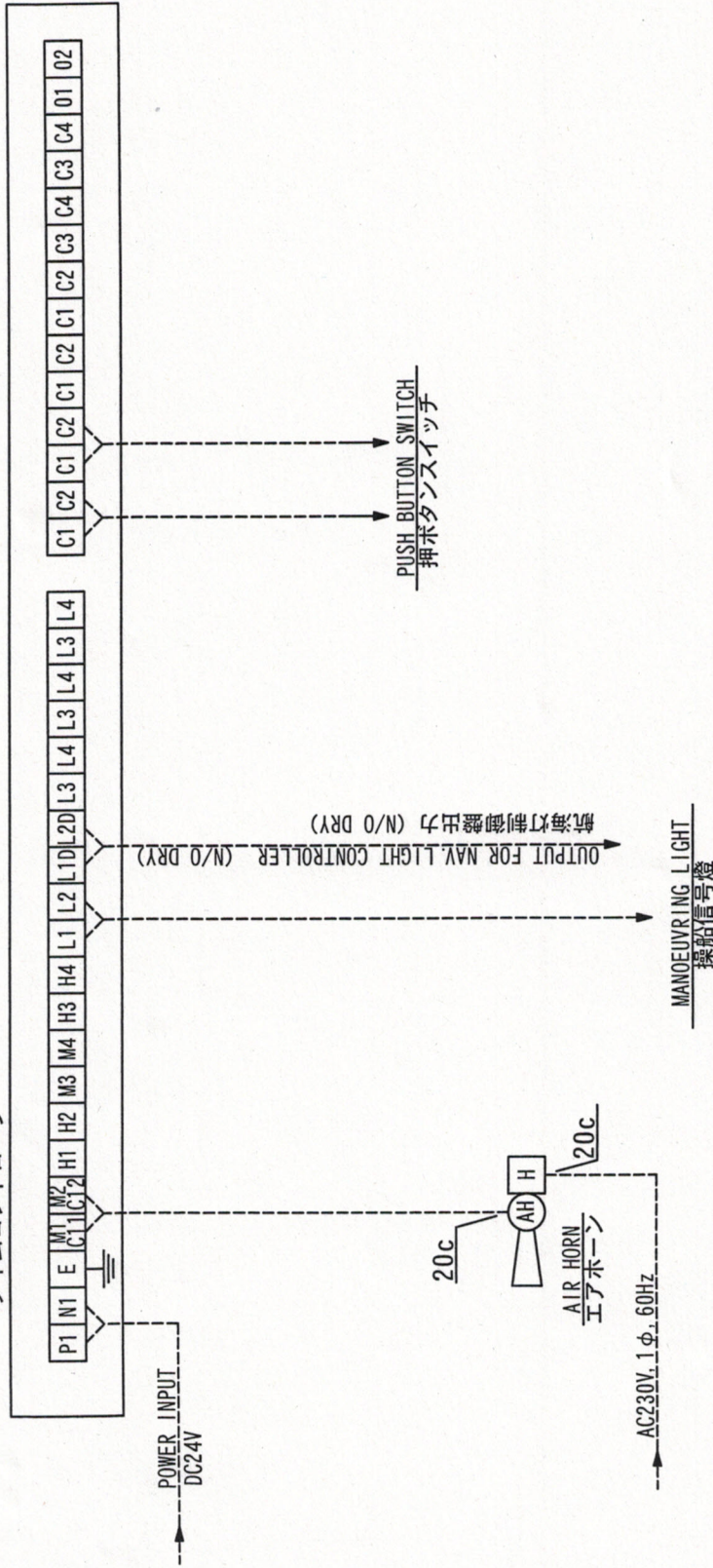

GENERAL EMERGENCY ALARM CIRCUIT 一般非常警報回路

GENERATOR INCLUDING TYPE / 発振回路内蔵式

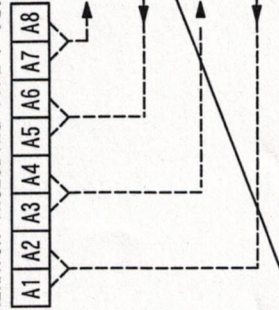

SIGNAL INPUT TYPE / 信号入力方式

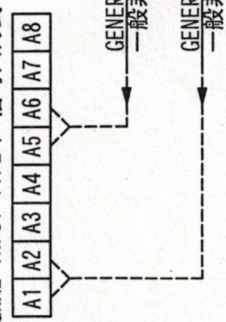

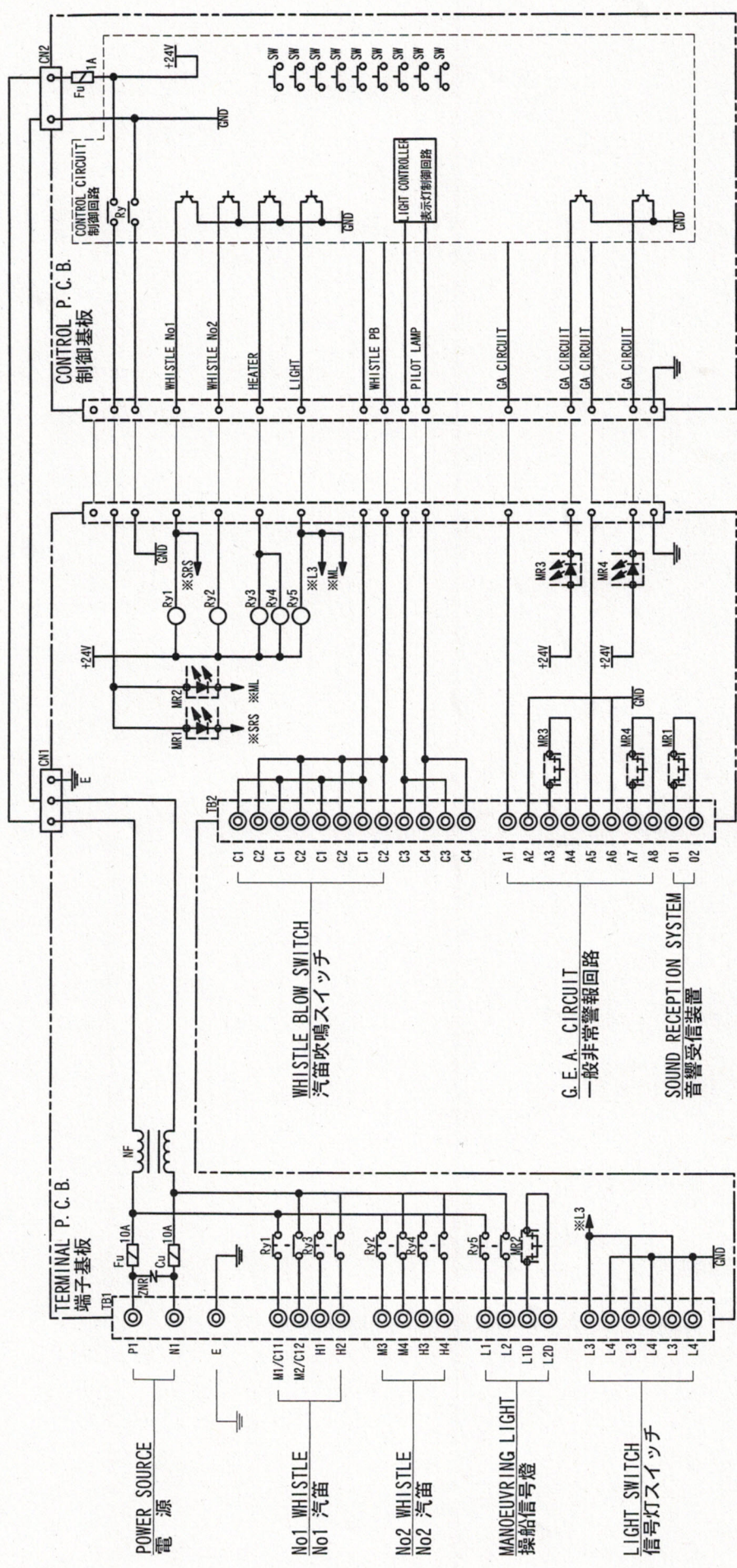

MR	MOS FET Relay	
Ry	Relay	
NF	Noise Filter	
Fu	Fuse	
ZNR	Varistor	
D. W. N. C. Shintaku	DATE	JAN. -13. 2012
C. K. D.	SCALE	1/2
C. K. D.	DWG. NO	SWJ-STM-8Z-2

WIRING DIAGRAM
接続図

WHISTLE
TIME CONTROLLER
汽笛
タイムコントローラ

STM-8Z

IBUKI KOGYO CO., LTD.
伊吹工業株式会社

